

MAGNALOCK USA

Innovative Workholding Solutions

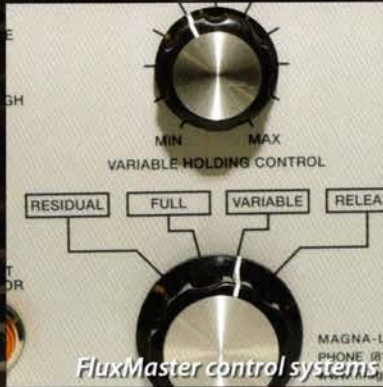

battery-operated lift magnets



FluxMaster control systems



accessories



sine chucks



repairs



electromagnetic chucks



permanent magnetic chucks



electric lift magnets



vacuum chucks

direct sales • repairs

815.962.8700 • magnalock.com

MAGNALOCK

USA



David Nordman
President

Magna-Lock USA, Inc. is a manufacturer of high-quality workholding solutions for a variety of manufacturing industries. Many of our customers specialize in the aerospace, automotive, woodworking and metalworking industries; while others are steel corporations, tooling and machining companies and businesses in the plastics industry. No customer is too large or too small to benefit from our products and services. We understand and appreciate the many challenges our customers face regarding workholding solutions to stay competitive and profitable.

We are proud to offer a full range of workholding equipment and accessories manufactured in the heartland of the United States of America. Our Mid-West location sets us apart from many of our competitors because we are able to service our customers on either coast in a timely manner. We are committed to stock many of our most popular chucks, lift magnets and accessories. When our customers equipment is down, we can promptly ship what they need, to get them back up and profitable. Our repair services include quick turnaround times with a full 2 year warranty. We are the only location you can get genuine Magna-Lock replacement parts direct.

Thank you for giving us the opportunity to show you our current product lines. Many of our products date back to 1948 when our company first began. We are proud of the growth and expansion we have accomplished in our many years, particularly the acquisition of Magnetic Specialties Corporation. Personally, I have been directly working with the Magna-Lock product lines since 1997. Additionally, several of our employees have numerous years of experience with our products.

We have earned an excellent reputation for quality, reliability and service. We look forward to showing you our outstanding reputation.

MAGNALOCK

USA

2730 Eastrock Drive • Rockford, IL 61109

815.962.8700

Fax: 815.398.0285

magnalock.com

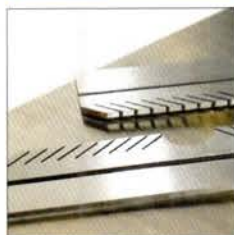
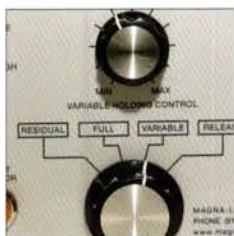
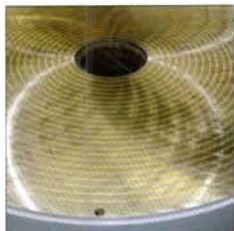

Electromagnetic Chucks4

- Transverse Pole
 - HU Series Universal 5
 - HG Series Grid 6
- Longitudinal Pole
 - HL Series Low Profile 7
 - HR Series 7
- Accessories for Electromagnetic Chucks 8
- Electromagnetic Sine
 - SE Series, Single 8
 - DE Series, Double 8
- HC Series, Rotary 9
- HB Series, Swiveling 10

Controls for Electromagnetic Chucks 11

- FluxMaster V Automatic Pulse Control 11
- FluxMaster IV Control with Manual Release 12

Vacuum Chucks 13

- MAV Series Rectangular 14
- MAV-RC Series, Rotary 15
- MAV-RS Series, Rotary 15
- MAV-W / MRV-W Series for Woodworking 16
- Accessories for Vacuum Chucks
 - Channel Seal Gasket 14
 - Rotary Coupling 15
 - Hose, Gauge, Dump 16
- Vacuum Systems 17

Permanent Magnetic Chucks 18

- Uni-Mesh 18
- Micro-Mesh 18
- Permanent Magnetic Sine
 - SP Series, Single 19
 - DP Series, Double 19

Magnetic Lifts20

- Power Grip Series 20
- Magna Lift Series 20
- Electric Lift Magnets 21

Repairs22

Electromagnetic Chucks

- Designed for a variety of industrial metalworking applications, from large-scale grinding to milling and planing
- Milled from solid metal to ensure fluid resistance

How To Order Electromagnetic Chucks

1. Specify type and size of chuck
2. Specify DC voltage (115 and 230 VDC standard)
3. Select size and type of FluxMaster Control and type of AC and DC voltage required (see pages 11–12)

Example:

- HL-618 Low Profile Chuck: 6" x 18"; 115 VDC
- F15MY1 FluxMaster Control: 115 VAC; 115 VDC

Electromagnetic Chuck Selection Guide

	HG Series Grid	HU Series Universal	HL Series Low Profile	HR Series Longitudinal Pole	HB Series Swiveling	HC Series Rotary
Milling	●			●	●	
Planing	●			●	●	
Grinding, General – 8x24 or Smaller			●			
Grinding, General – Larger Than 8x24	●					
Heavy Machining	●			●		
Knife Grinding	●				●	
Rotary Grinding Lathe						●
Angular Machining					●	
Small or Thin Workpieces Use With Parallels or V-Blocks		●	●	●		

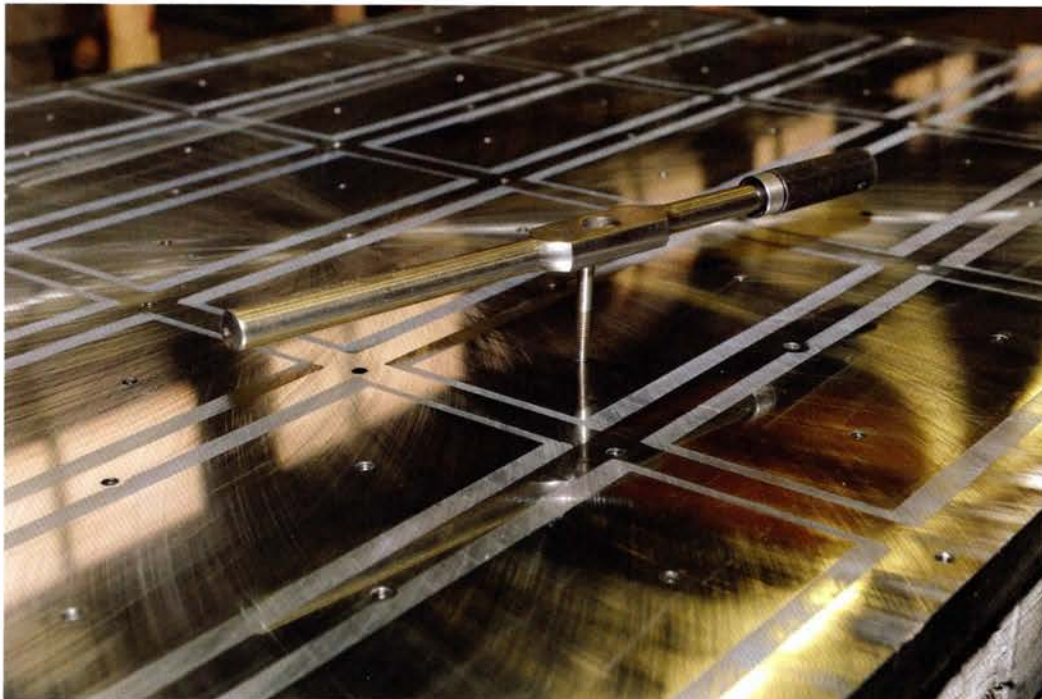

Electromagnetic Chucks

Transverse Pole Electromagnetic Chucks



HU Series Universal Chucks

- Closely-spaced transverse magnetic pole pattern
- Magnetic poles extend fully to front and back edges for maximum holding area
- Recommended for holding small or thin workpieces
- Ideally suited for use with parallels or V-blocks (see page 8)
- Use with appropriate FluxMaster Control (see pages 11-12)

HU Series – Specifications

Model	Work Surface		Height		Weight		Watts
	in	mm	in	mm	lb	kg	
HU-612	6 x 12	152 x 305	4.00	102	59	27	80
HU-618	6 x 18	152 x 457	4.00	102	108	49	125
HU-818	8 x 18	203 x 457	4.00	102	144	65	150
HU-824	8 x 24	203 x 610	4.00	102	192	87	190
HU-1024	10 x 24	254 x 610	5.00	127	240	109	240
HU-1030	10 x 30	254 x 762	5.00	127	300	136	310
HU-1224	12 x 24	305 x 610	5.25	133	378	171	285
HU-1230	12 x 30	305 x 762	5.25	133	473	215	390
HU-1236	12 x 36	305 x 914	5.25	133	567	257	430
HU-1248	12 x 48	305 x 1219	5.25	133	756	343	550
HU-1260	12 x 60	305 x 1524	5.25	133	945	429	720
HU-1448	14 x 48	356 x 1219	5.25	133	882	400	700
HU-1460	14 x 60	356 x 1524	5.25	133	1103	500	895
HU-1636	16 x 36	406 x 914	5.25	133	756	343	550
HU-1648	16 x 48	406 x 1219	5.25	133	1008	457	760
HU-1660	16 x 60	406 x 1524	5.25	133	1260	572	985
HU-1836	18 x 36	457 x 914	5.25	133	851	386	660
HU-1848	18 x 48	457 x 1219	5.25	133	1134	514	885
HU-1860	18 x 60	457 x 1524	5.25	133	1418	643	1080

HU Series – Dimensions

	Chuck Width	
	Under 12"	12" or over
Magnetic Pole Width	.125"	.250"
Non-Magnetic Separator Width	.03125"	.125"
Total Pitch	.15625"	.375"

NOTE: All measurements are approximate.

Electromagnetic Chucks

Transverse Pole Electromagnetic Chucks

HG Series Grid Chucks

- For medium and large grinders, plus milling and planing
- Evenly distributes magnetic holding over entire surface
- Rectangular pole sections sized for maximum holding
- Styles include:
 - Grid-to-one-edge: magnetic poles extended over front or back edge
 - Grid-to-two-edge: magnetic poles extended over both front and back edges
- Use with appropriate FluxMaster Control (see pages 11–12)



HG Series – Dimensions

	Series	
	G	H
Magnetic Pole Width	.50"	.75"
Non-Magnetic Separator Width	.1875"	.25"
Total Pitch	.6875"	1.00"

All measurements are approximate.

HG Series – Specifications

Model	Work Surface		Height		Weight		Watts
	in.	mm	in.	mm	lb	kg	
HG-824G	8 x 24	203 x 610	4.00	102	215	98	150
HG-836G	8 x 36	203 x 914	4.00	102	288	131	220
HG-1015G	10 x 15	254 x 381	5.00	127	160	73	100
HG-1024G	10 x 24	254 x 610	5.00	127	250	113	160
HG-1030G	10 x 30	254 x 762	5.00	127	285	129	200
HG-1036G	10 x 36	254 x 914	5.00	127	385	175	280
HG-1048G	10 x 48	254 x 1219	5.00	127	485	220	375
HG-1060G	10 x 60	254 x 1524	5.00	127	750	340	465
HG-1224G	12 x 24	305 x 610	5.00	127	325	147	200
HG-1230G	12 x 30	305 x 762	5.00	127	400	181	240
HG-1236G	12 x 36	305 x 914	5.00	127	480	218	290
HG-1240G	12 x 40	305 x 1016	5.00	127	525	238	300
HG-1248G	12 x 48	305 x 1219	5.00	127	615	279	395
HG-1260G	12 x 60	305 x 1524	5.00	127	750	340	500
HG-1424G	14 x 24	356 x 610	5.00	127	400	181	200
HG-1436G	14 x 36	356 x 914	5.00	127	600	272	300
HG-1448G	14 x 48	356 x 1219	5.00	127	765	347	475
HG-1460G	14 x 60	356 x 1524	5.00	127	950	431	545
HG-1624G	16 x 24	406 x 610	5.25	133	450	204	290
HG-1636G	16 x 36	406 x 914	5.25	133	700	318	400
HG-1648G	16 x 48	406 x 1219	5.25	133	950	431	535
HG-1660G	16 x 60	406 x 1524	5.25	133	1200	544	730
HG-1824G	18 x 24	457 x 610	5.25	133	530	240	320
HG-1836G	18 x 36	457 x 914	5.25	133	865	392	450
HG-1848G	18 x 48	457 x 1219	5.25	133	1200	544	600
HG-1860G	18 x 60	457 x 1524	5.25	133	1525	692	750
HG-2024H	20 x 24	508 x 610	5.25	133	600	272	300
HG-2036H	20 x 36	508 x 914	5.25	133	1000	454	475
HG-2048H	20 x 48	508 x 1219	5.25	133	1400	635	720
HG-2060H	20 x 60	508 x 1524	5.25	133	1700	771	750
HG-2436H	24 x 36	610 x 914	5.25	133	1200	544	500
HG-2448H	24 x 48	610 x 1219	5.25	133	1550	703	780
HG-2460H	24 x 60	610 x 1524	5.25	133	1825	829	1000
HG-3036H	30 x 36	762 x 914	5.50	140	1550	703	750
HG-3048H	30 x 48	762 x 1219	5.50	140	2050	930	1000
HG-3060H	30 x 60	762 x 1524	5.50	140	2600	1179	1225
HG-3636H	36 x 36	914 x 914	5.50	140	1685	764	900
HG-3648H	36 x 48	914 x 1219	5.50	140	2246	1019	1150
HG-3660H	36 x 60	914 x 1524	5.50	140	2700	1225	1500
HG-4248H	42 x 48	1067 x 1219	5.75	146	2620	1188	1400
HG-4260H	42 x 60	1067 x 1524	5.75	146	3270	1483	1650
HG-4848H	48 x 48	1219 x 1219	5.75	146	2995	1359	1500
HG-4860H	48 x 60	1219 x 1524	5.75	146	3744	1698	1875

Note: 60" is maximum recommended length for magnetic chucks. For larger sizes, use a combination of above sizes.

Electromagnetic Chucks

Longitudinal Pole Electromagnetic Chucks

HL Series Low-Profile Chucks

- Longitudinal fine pole pattern for full magnetic surface to all edges
- Lowest height available in the industry, providing more head room on grinder for jigs and fixtures
- Recommended for small and thin workpieces
- Ideally suited for use with parallels and v-blocks (see page 8)
- Use with appropriate FluxMaster Control (see pages 11–12)



HL Series – Specifications

Model	Work Surface		Height		Weight		Watts
	in	mm	in	mm	lb	kg	
HL-510	5 x 10	127 x 254	3	76	38	17	36
HL-512	5 x 12	127 x 305	3	76	46	21	48
HL-612	6 x 12	152 x 305	3	76	55	25	53
HL-614	6 x 14	152 x 356	3	76	64	29	68
HL-618	6 x 18	152 x 457	3	76	83	37	85
HL-818	8 x 18	203 x 457	3	76	110	49	107
HL-824	8 x 24	203 x 610	3	76	147	66	150
HL-1015	10 x 15	254 x 381	3	76	115	52	120
HL-1018	10 x 18	254 x 457	3	76	130	55	135
HL-1024	10 x 24	254 x 610	3	76	185	83	150
HL-1030	10 x 30	254 x 762	3	76	231	104	217
HL-1224	12 x 24	305 x 610	3	76	222	100	150

HL Series – Dimensions*

	Chuck Width
Magnetic Pole Width	.125"
Non-Magnetic Separator Width	.03125"
Total Pitch	.15625"

*NOTE: All measurements are approximate.

Longitudinal Pole Electromagnetic Chucks

HR Series

- Same top plate pattern as HL Series in models less than 12" wide
- Excellent stability for heavy machining and grinding
- Ideally suited for use with parallels and v-blocks
- Excellent holding for special fixtures and jigs
- Use with appropriate FluxMaster Control (see pages 11–12)



HR Series – Specifications

Model	Work Surface		Height		Weight		Watts
	in	mm	in	mm	lb	kg	
HR-510	5 x 10	127 x 254	4	102	50	23	40
HR-612	6 x 12	152 x 305	4	102	72	32	50
HR-618	6 x 18	152 x 457	4	102	108	49	80
HR-818	8 x 18	203 x 457	4	102	144	65	100
HR-824	8 x 24	203 x 610	4	102	192	87	150
HR-1015	10 x 15	254 x 381	4	102	150	68	100
HR-1024	10 x 24	254 x 610	5	127	240	109	200
HR-1030	10 x 30	254 x 762	5	127	300	136	240
HR-1224	12 x 24	305 x 610	5.25	133	378	171	235
HR-1230	12 x 30	305 x 762	5.25	133	473	215	300
HR-1236	12 x 36	305 x 914	5.25	133	567	257	325
HR-1248	12 x 48	305 x 1219	5.25	133	756	343	460
HR-1436	14 x 36	356 x 914	5.25	133	662	300	460
HR-1448	14 x 48	356 x 1219	5.25	133	882	400	500
HR-1460	14 x 60	356 x 1524	5.25	133	1103	500	750
HR-1636	16 x 36	406 x 914	5.25	133	756	343	495
HR-1648	16 x 48	406 x 1219	5.25	133	1008	457	695
HR-1660	16 x 60	406 x 1524	5.25	133	1260	572	750
HR-1836	18 x 36	457 x 914	5.25	133	851	386	520
HR-1848	18 x 48	457 x 1219	5.25	133	1134	514	750
HR-1860	18 x 60	457 x 1524	5.25	133	1418	643	980

HR Series – Dimensions

	Chuck Width	
	Under 12"	12" or over
Magnetic Pole Width	.125"	.250"
Non-Magnetic Separator Width	.03125"	.125"
Total Pitch	.15625"	.375"

*NOTE: All measurements are approximate.

Electromagnetic Chucks

Electromagnetic Chuck Accessories

Magna-Vise

- Holds rigid non-magnetic materials such as brass, copper, plastic, aluminum, etc.
- Easy to use

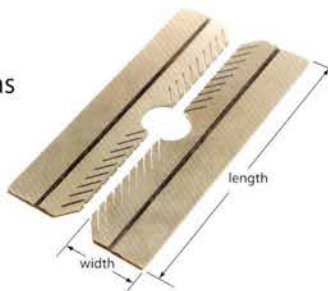

Magna-Vise – Specifications

Model	Length		Width		Thickness	
	in.	mm	in.	mm	in.	mm
MV-6	6.375	162	1.5625	40	0.155	4
MV-6-A	6.375	162	1.5625	40	0.100	2.5
MV-10	10	254	1.5625	40	0.155	4
MV-14	14	356	1.5625	40	0.155	4

Magnetic Parallels and 90° V-Blocks

- Acting as transfer plates, allows magnetism to be transmitted to workpiece
- Eliminate the need for special clamping devices
- Ideally suited for use on HU Series Universal Chucks and Longitudinal Chucks Series HL and HR
- Transverse pole standard
- Additional sizes and styles available upon request

V-Blocks – Specifications

Model	Length		Width		Height	
	in.	mm	in.	mm	in.	mm
MV-1	2.5	64	2.5	64	1.75	45
MV-2	4	102	2.5	64	1.75	45
MV-3	6	152	6	152	2	51
MV-4	6	152	2.5	64	1.75	45

Magnetic Parallels – Specifications

Model	Dimensions		Weight	
	in.	mm	lb	kg
M-2	.75 x 1.5 x 6	19 x 38 x 152	2.25	1.01
M-3	1 x 2 x 4	25 x 51 x 102	2.75	1.24
M-4	1 x 2 x 6	25 x 51 x 152	4	1.80
M-5	1 x 3 x 6	25 x 76 x 152	6	2.70
M-28	1 x 2 x 8	25 x 51 x 203	5.75	2.59
M-38	1 x 3 x 8	25 x 76 x 203	7.5	3.38
M-46	1 x 4 x 6	25 x 102 x 152	8	3.60

Electromagnetic Sine Chuck

SE and DE Series

- For accurate angular machining, layout and inspection work
- Available in single angle (SE Series) or compound angle (DE Series)
- Each unit supplied with an inspection report and table of sine constants
- Comes equipped with:
 - Hardened gage pads to accommodate gage blocks
 - Right-hand screws for positive hinge roll locking
 - Removable end and back stops
- Other sizes, top plate patterns and hinge arrangements available upon request



SE Series, Single Angle – Specifications

Model	Work Surface (in.)	Height (in.)	Wt. (lb)	Watts
SE-606L	6 x 6	4-3/4	45	24
SE-612L	6 x 12	4-3/4	91	37
SE-618L	6 x 18	5-5/8	137	62

NOTE: Sine accuracy can be found on page 19 of this catalog.



DE Series, Compound Angle – Specifications

Model	Work Surface (in.)	Height (in.)	Wt. (lb)	Watts
DE-606L	6 x 6	6-1/8	56	24
DE-612L	6 x 12	6-1/8	105	37
DE-618L	6 x 18	7-1/2	158	62

Electromagnetic Chucks

Rotary Electromagnetic Chucks

HC Series

- For use on surface grinders, lathes, cylindrical grinders and other machines
- Cover has concentric ring pattern for holding down to 2.25" diameter
- Collector ring and brush holder assemblies included
- Collector rings on Type II sizes (30" and larger) located in center of chuck for easy access
- Assemblies on smaller and special chucks can be arranged to customer specifications
- Removable sealed center cover on Type II chucks allows access to cover ring
- Type 1 models feature 7.5" diameter removable bronze (non-magnetic) center cover for access to collector ring
- Use with appropriate FluxMaster Control (see pages 11 – 12)



HC Series – Specifications

Model	Work Surface		Height		Weight		Watts
	sq. in.	sq. mm	in.	mm	lb	kg	
HC-30	30.875	784	5.5625	141	900	408	655
HC-36	36.875	937	5.5625	141	976	443	980
HC-42	42.875	1089	5.5625	141	1500	680	1380
HC-48	48.875	1241	5.5625	141	2350	1066	1750
HC-54	54.75	1089	5.5625	141	2900	1315	1835
HC-60	60.875	1546	5.5625	141	3700	1678	2085
HC-72	72.125	1832	5.5625	141	5200	2359	3030
HC-84	84	2134	5.5625	141	7100	3220	4255
HC-96	96	2438	5.5625	141	9350	4241	5750

HC Series – Dimensions

	Model	
	HC-30 to HC-54	HC-60 to HC-96
Magnetic Pole Width	.50"	.75"
Non-Magnetic Separator Width	.1875"	.25"
Total Pitch	.6875"	1"

NOTE: All measurements are approximate.

Rotary Electromagnetic Chucks

Replacement Parts



Replacement Parts for Rotary Electromagnetic Chucks

Part No.	Description
198847	1/2" Brush Holder Assembly
197291	Standard 1/2" Collector Ring Assembly
198308	3/4" Brush Holder Assembly
203990	3/4" Collector Ring Assembly
198857	1/2" Brush Assembly Replacement Kit
199911	Smith Rubber Gasket
199918	3/4" Brush Assembly Replacement Kit
199993	Standard Brass Cover Plate
369234	Rotating Elec. Connector
226-4004-50	O-Ring

Electromagnetic Chucks

Swiveling Electromagnetic Chucks

HB Series

- Positive locking at desired angular setting
- Balanced for easy rotation through 360°
- 5x10 and 6x18 models provided with brackets only
- Larger models supplied with brackets, protractor dial, worm gear assembly with handwheel and optional ratchet handle
- Use with appropriate FluxMaster Control (see pages 11-12)

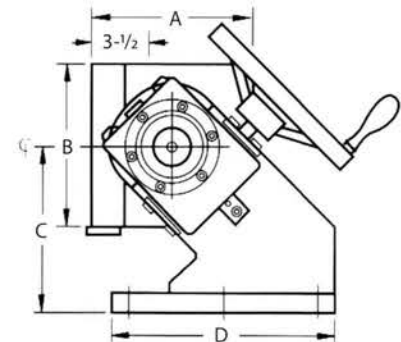
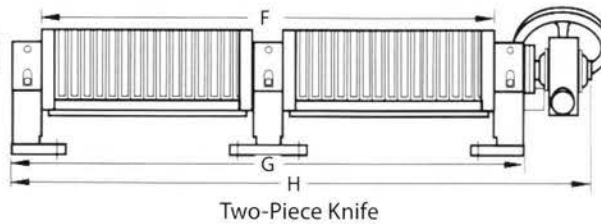
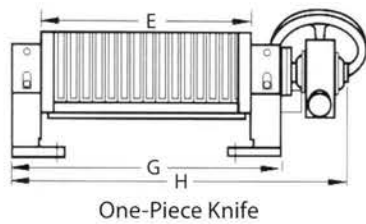

HB Series – Specifications

Model	A	B	C	D	E	F	G	H	Weight	
									lb	Watts
HB-510C	4	5	4.25	–	10	–	17	–	85	39
HB-618C	4	6	4.25	–	18	–	25	–	135	79
HB-632AG	4.25	6.125	5.25	8.1875	32	–	41.625	–	275	126
HB-638AG	4.25	6.125	5.25	8.1875	38	–	47.625	–	300	138
HB-648AG	4.25	6.125	5.25	8.1875	48.25	48.25	57.875	–	350	200
HB-654AG	4.25	6.125	5.25	8.1875	54.25	54.25	63.875	–	400	220
HB-632G	6.25	6.75	5.25	8.5	32	–	39.125	46.875	375	149
HB-638G	6.25	6.75	5.25	8.5	38	–	45.125	52.875	400	158
HB-644G	6.25	6.75	5.25	8.5	44	–	51.125	58.875	425	200
HB-650G	6.25	6.75	5.25	8.5	50	50	57.125	64.875	450	200
HB-656G	6.25	6.75	5.25	8.5	56	56	63.125	70.875	490	300
HB-662G	6.25	6.75	5.25	8.5	62	62	69.125	76.875	530	300
HB-848G	8.125	8.125	10.25	14.3125	47.875	–	55.875	64.125	980	251
HB-860G	8.125	8.125	10.25	14.3125	60	–	68	76.25	1200	317
HB-872G	8.125	8.125	10.25	14.3125	72	72	80	88.25	1300	377
HB-884G	8.125	8.125	10.25	14.3125	–	84	92	100.25	1450	419
HB-1048H	10.125	10.125	10.25	15.3125	48	–	56	64.25	1510	392
HB-1060H	10.125	10.125	10.25	15.3125	60	–	68	76.25	2050	472
HB-1072H	10.125	10.125	10.25	15.3125	72	72	80	88.25	2650	600
HB-1084H	10.125	10.125	10.25	15.3125	84	84	92	100.25	3200	707



Controls for Electromagnetic Chucks

FluxMaster V Automatic Multi-Pulse Control

- Provides rectified DC power and control for all makes of electromagnetic chucks
- Four-position rotary switch for full power, variable power, residual holding, and release (automatic demagnetization) modes
- 0 to 100% variable holding standard
- Rugged enclosures protect against dust, dirt, oil and water
- Control panel can be conveniently located at front of machine



SCC Series: Self-Contained FluxMaster V

- 150 to 300 watt ratings
- 115/230 volts AC (60 Hz 10) input
- Single cabinet contains both control panel and balance of electrical components

SCC Series – Specifications

Model No.	Watts	Max. Output Volts DC*	Weight	
			lb	kg
SCC-115-150S	150	115	21	10
SCC-115-300S	300	115	30	14
SCC-230-150S	150	230	21	10
SCC-230-300S	300	230	30	14

*100% setting

CC Series: Remote-Controlled FluxMaster V

- 300 to 10,000 watt ratings
- 230/460 volts AC (60 Hz 10) input
- All electrical controls and power functions housed in wall-mounted enclosure
- Remote control station allows mounting position convenient to operator
- Includes four-position rotary switch, 0 to 100% variable holding control and pilot lights for visual information
- Optional stand kit available
- Fused disconnect switches
- Terminals for simplified wiring connections

CC Series – Specifications

Model No.	Watts	Max. Output Volts DC*	Weight		Enclosure Size**
			lb	kg	
CC-115-300S	300	115	115	52	B1
CC-230-300S	300	230	115	52	B1
CC-115-500S	500	115	115	52	B1
CC-230-500S	500	230	115	52	B1
CC-115-750S	750	115	115	52	B2
CC-230-750S	750	230	115	52	B2
CC-115-1000S	1000	115	130	59	B2
CC-230-1000S	1000	230	130	59	B2
CC-115-1500S	1500	115	190	86	B2
CC-230-1500S	1500	230	190	86	B2
CC-230-2000S	2000	230	220	100	B2
CC-230-3000S	3000	230	290	132	B2
CC-230-5000S	5000	230	350	159	B3
CC-230-7500S	7500	230	420	191	B3
CC-230-10000S	10000	230	420	191	B3

*100% setting

** See table on following page

Controls for Electromagnetic Chucks



Accessories

Remote-Controlled Cabinet Unit



- For FluxMaster V models only

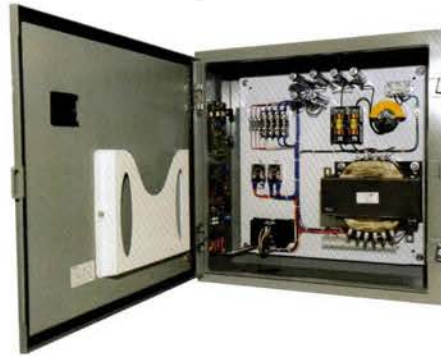

Enclosures – Specifications

Dimensions	Enclosure B1		Enclosure B2		Enclosure B3	
	in.	mm	in.	mm	in.	mm
Width	20	508	24	610	24	610
Height	20	508	24	610	30	762
Depth	7	178	11	279	13	330

Floor Stand Kits for Remote-Controlled Units

- Includes two sturdy 18" high stands
- Stands bolt to underside of control cabinet
- Pre-drilled holes facilitate mounting stand to floor

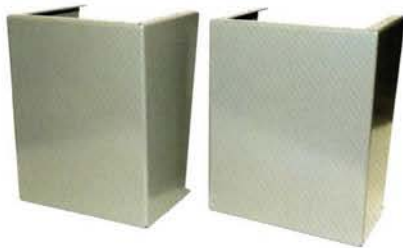
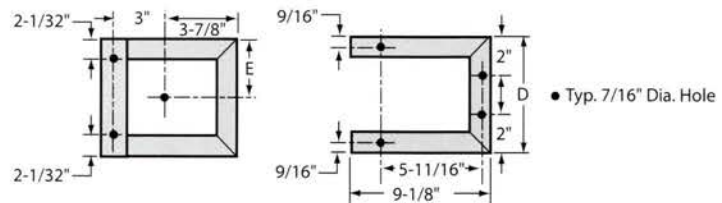

Floor Stand Kits – Specifications

Enclosure Size	Use Model No.	Dimension D		Dimension E		Weight	
		in.	mm	in.	mm	lb	kg
B1	HFK-1808	8	203	4	102	8.5	3.9
B2	HFK-1810	10	254	5	127	10	4.5
B3	HFK-1812	12	305	6	152	12	5.5

NOTE: Avoid damaging components and wiring when drilling bolt holes.

Controls for Electromagnetic Chucks

FluxMaster IV Control with Manual Release

- Manually operated control
- Simpler and less expensive than FluxMaster V
- Three-position toggle switch
 - Toggle-right provides DC current for energizing chuck
 - Variable control knob-setting determines DC output
 - Toggle center turns off current to chuck
 - Toggle left reverses current to release workpiece
- Includes 6' three-wire AC cord and plug, and 6' DC power cord

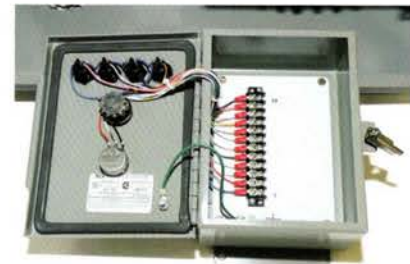

FluxMaster IV – Specifications

Model No.	Watts	Input Volts AC	Max. Output Volts DC	Weight	
				lb	kg
F15MY1	150	115	0-115	9	4

Magna-Lock Vacuum Chucks

- Apply the concept of negative pressure
- Hold all non-porous materials, including ferrous, non-ferrous and non-metallic materials in virtually any configuration, including sheets, plates, shapes and extrusions
 - Can be used with titanium, copper, steel, stainless steel, aluminum, wood, laminate, glass or plastic
- Holding power to 13 psi
- Ensure accuracy – workpieces are registered directly on the face of the chuck as opposed to suspended on O-rings or fixed seals
- Eliminate use of costly, cumbersome jigs and clamps
- Compact size, simple design and versatility improve production and increase output
- Available in a wide variety of standard sizes to fit most existing machining and assembly equipment
 - Can be used with equipment beds up to 10' wide and 40' long
- Can be made with channels, orifices, manifolds and seals as required
- Made of dimensionally-stable cast aluminum tooling plate
- Feature time-saving instant reaction
- Easy to install
- Custom-fit pieces available - contact a Magna-Lock sales engineer to design your optimal workholding solution

How to Order Vacuum Chucks

1. Specify model, type and size of unit.
2. Select vacuum system and accessories
3. Specify voltage requirements for vacuum system

Example:

- (1) MAV-1224 Rectangular Vacuum Chuck with steel back
- (1) TV-171 Vacuum System; 115 volts, 60 Hz, 1 phase
- (1) TV-110 combination vacuum gauge and dump valve
- (10 feet) vacuum hose
- (2 pair) hose barbs
- (50 feet) 1/8 x 13/16 Channel-Seal gasket

Vacuum Chuck Holding Force

(Based on vacuum of 26 inches of mercury or approximately 13 psi)

Chuck Size	Holding Force
1 square inch	13 lb
5 square inches	65 lb
6 square inches	78 lb
1 square foot	1,872 lb
5 square feet	4.7 tons
8 feet x 20 feet	150 tons



Vacuum Chucks for Metalworking MAV Series Rectangular Vacuum Chucks

- Vacuum inlet port, 1/4" NPT, in end of chuck is standard
- Easy mounting with machined carbon steel base plate or clamping grooves
- Parallelism and flatness to commercial aluminum tooling plate tolerances
- Channel-Seal provides positive, simple sealing

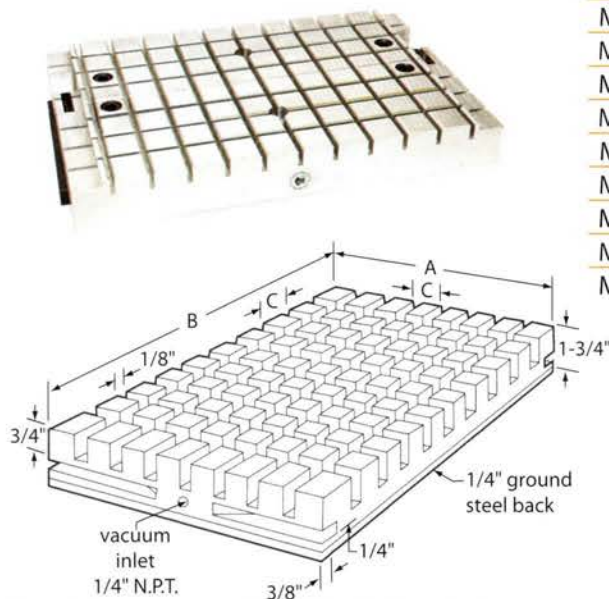

MAV Series Rectangular Chucks – Specifications

Model	Width (A)		Length (B)		Groove Pattern (C)		Weight		No. of Ports
	in.	mm	in.	mm	in.	mm	lb	kg	
MAV-510	5	127	10	254	0.5	13	11	5	1
MAV-608	6	152	8	203	0.5	13	10.5	5	1
MAV-612	6	152	12	304	0.5	13	16	7	2
MAV-615	6	152	15	381	0.75	19	20	9	2
MAV-618	6	152	18	457	0.75	19	24	11	3
MAV-812	8	203	12	304	0.75	19	21	10	2
MAV-815	8	203	15	381	0.75	19	26	12	2
MAV-818	8	203	18	457	0.75	19	32	15	3
MAV-824	8	203	24	610	0.75	19	42	19	4
MAV-1015	10	254	15	381	1	25	33	15	2
MAV-1020	10	254	20	508	1	25	43	20	3
MAV-1024	10	254	24	610	1	25	53	24	4
MAV-1030	10	254	30	762	1	25	66	30	5
MAV-1218	12	305	18	457	1	25	47	21	6
MAV-1224	12	305	24	610	1	25	64	29	8
MAV-1230	12	305	30	762	1	25	79	36	10
MAV-1236	12	305	36	914	1	25	94	43	12
MAV-1248	12	305	48	1219	1	25	126	57	16

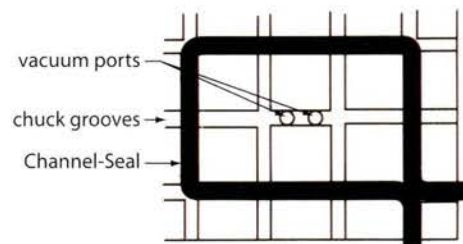

Accessories for Vacuum Chucks

Channel-Seal Gasket

- Resilient sponge rubber seal strip
- Installed in the grooves of a vacuum chuck to obtain the vacuum seal under workpiece
 - Should enclose the largest possible area of the workpiece for maximum holding force
- Sold in 50-foot standard length coils only



When ordering, please consider the following:

- Wrong-sized Channel-Seal may leak if too low or too high. Normally, it should extend 1/32" above the chuck.
- An insufficient seal can also be caused by Channel-Seal that is worn, torn, aged or stretched too far during installation
- Non-standard sizes can be special-ordered in large quantities only

Channel-Seal – Specifications

Part No.	Size (in.)	Part No.	Size (in.)
363000	1/16 x 9/32	363015	1/8 x 13/16
363001	1/16 x 17/32	363016	1/8 x 27/32
363002	1/16 x 25/32	363017	1/8 x 7/8
363003	1/4 x 7/16	363019	1/8 x 15/16
363004	1/8 x 5/32	363026	1/8 x 1-5/32
363005	1/8 x 9/32	363027	1/8 x 1-9/32
363006	1/8 x 5/16	363028	1/8 x 15/32
363007	1/8 x 3/8	363029	1/8 x 9/16
363008	1/8 x 7/16	363030	1/4 x 9/32
363009	1/8 x 17/32	363031	1/4 x 5/16
363010	1/8 x 5/8	363032	1/4 x 3/8
363011	1/8 x 21/32	363033	1/4 x 17/32
363013	1/8 x 3/4	363034	1/4 x 25/32
363014	1/8 x 25/32	363243	1/8 x 1/2

Normal thickness tolerances

1/8"	+0.032"/-0.016"
1/4"	± .032

Normal height tolerances

1" or under	±.032"
-------------	--------

Vacuum Chucks

Vacuum Chucks for Metalworking MAV-RC and MAV-RS Series Standard Rotary Vacuum Chucks

- Extend the use of grinders, lathes, indexing table and other rotary material
- Especially well-suited for use with rotary table surface grinders
- Available in two standard groove configurations, both incorporating Channel Seal (see page 14)
 - Concentric circular
 - Square grid
- Standard groove is 1/8" wide and 1/2" deep
- Holds one or more workpieces of various sizes and shapes
- Diameters available to fit virtually any machine
- Low overall height: 1-1/2" to 1-3/4"
- Closed back for mounting on flat surfaces
 - Can bolt to flat or T-slotted surfaces, be held by magnetic chucks, or utilize chuck's vacuum
 - Open back models available
- 1/4" NPT vacuum inlet
- Rotating coupling required for rotating applications

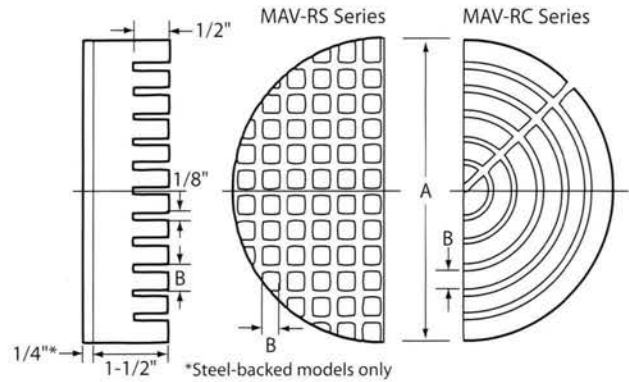

MAV-RC Series, Circular Pattern – Specifications

Model	Width (A)		Groove Pattern (B)		Weight	
	in.	mm	in.	mm	lb	kg
MAV-6RC	6	152	0.5	13	9	4
MAV-8RC	8	203	0.5	13	11	5
MAV-10RC	10	254	0.5	13	17	8
MAV-12RC	12	305	0.5	13	25	11
MAV-14RC	14	356	0.75	19	34	15
MAV-16RC	16	406	0.75	19	43	20
MAV-18RC	18	457	0.75	19	55	25
MAV-20RC	20	508	0.75	19	70	32
MAV-24RC	24	610	1	25	99	45
MAV-30RC	30	762	1	25	154	70
MAV-36RC	36	915	1	25	222	101

MAV-RS Series, Grid Pattern - Specifications

Model	Width (A)		Groove Pattern (B)		Weight	
	in.	mm	in.	mm	lb	kg
MAV-6RS	6	152	0.5	13	9	4
MAV-8RS	8	203	0.5	13	11	5
MAV-10RS	10	254	0.5	13	17	8
MAV-12RS	12	305	0.5	13	25	11
MAV-14RS	14	356	0.75	19	34	15
MAV-16RS	16	406	0.75	19	43	20
MAV-18RS	18	457	0.75	19	55	25
MAV-20RS	20	508	0.75	19	70	32
MAV-24RS	24	610	1	25	99	45
MAV-30RS	30	762	1	25	154	70
MAV-36RS	36	915	1	25	222	101

Accessories for Vacuum Chucks Rotating Coupling

- For use with rotating chucks on lathes, grinders, shapers, polishers, routers, profilers and other rotary applications
- Provides simple, free-turning sealed rotary connection between rotating chuck and vacuum system
- Hardened rotor and Oilite bearings require no lubrication

Rotary Couplings – Specifications

Model	Standard Pipe Thread	RPM Maximum
TV-130	1/4"	250
TV-131	3/8"	1000
TV-132	1/2"	1000



Vacuum Chucks for Woodworking

MAV-W and MRV-W Series Vacuum Chucks

- Ideal for use with multiple carvers, profilers, routers, lathes, shapers, polishers, drum sanders, rosette cutters, drill presses, boring machines, and hand and portable tool work
- Work can be machined to templates with desired patterns or contours for multiple production of parts
- Eliminate costly set-up and changeover time
- Eliminate surface-marring clamps and fixtures
- Recommended vacuum supply system for models listed here is TV-171S
- Dump valves, rotary couplings, etc. available at extra cost
- Standard groove is 1/8" wide by 1/4" deep
- 1/8" x 9/32" Channel Seal recommended
- Additional models available with abrasive or rubberized work surfaces

MRV-W Series, Round Woodworking Chucks – Specifications

Model	Diameter		Length		Groove Pattern		Weight	
	in.	mm	in.	mm	in.	mm	lb.	kg
MRV-6W	6.5	165	1	25	1.5	38	2.8	1.3
MRV-9W	9.5	241	1	25	2	51	6.4	2.9
MRV-12W	12.5	317	1	25	2	51	11.4	5.1

MAV-W Series, Square Woodworking Chucks – Specifications

Model	Diameter		Length		Groove Pattern		Weight	
	in.	mm	in.	mm	in.	mm	lb.	kg
MAV-606W	6	152	1	25	.5	13	3.6	1.6
MAV-909W	9	229	1	25	.5	13	8.2	3.7
MAV-1212W	12	305	1	25	1	25	14.5	6.5

Accessories for Vacuum Chucks

Vacuum Hose

- Heavy-duty vacuum hose with male pipe thread-fitting at each end
- Specify desired length when ordering

Vacuum Hose – Specifications

Model	Standard Pipe Thread
TV-2	1/4"
TV-3	3/8"
TV-5	1/2"

Vacuum Gauge

- Shows vacuum from 0-30" mercury
- Allows operator to monitor vacuum as it holds workpiece

Vacuum Gauge – Specifications

Model	Male Pipe Thread	Diameter	
		in.	mm
TV-120	1/4"	2	51

Vacuum Dump Valve

- Provides instant application and release of vacuum with minimal loss of vacuum from system
- Handle with short 90° throw assures fast chucking and release of workpieces, and provides selective control of manifold chucks
- Designed for easy installation at location convenient to operator



Dump Valve Only – Specifications

Model	Standard Pipe Thread
TV-101	1/4"
TV-102	3/8"
TV-103	1/2"

Vacuum Gauge and Dump Valve Assembly

- Model TV-101 dump valve plus TV-120 gauge
- Assembly drilled for convenient mounting on machine

Assembly – Specifications

Model	Standard Pipe Thread
TV-110	1/4"
TV-112	3/8"

Vacuum Systems

TV Series Automatic Vacuum Systems

- Supply negative (vacuum) pressure for all vacuum chucks
- Each system includes
 - vane-type vacuum pump
 - electric motor
 - steel reservoir tank and drain
 - vacuum check valve
 - adjustable pressure switch
 - inlet filter
 - exhaust muffler
- Shipped completely assembled with electrical connection box on motor
- Available with magnetic starter and selector switch
- Rated for 26" Hg maximum
- Adjustable activation and shut-off values
- Consult Magna-Lock for additional voltages and features

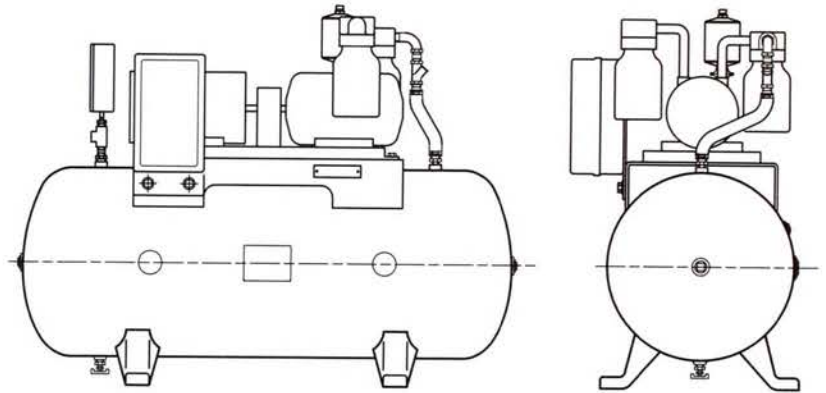

TV Series – Specifications

Model	CFM	HP	Reservoir Capacity		Shipping Weight		Electrical Input
			gal.	ltr.	lb	kg	
TV-171	4	1/4	12	45	95	43	115V-60Hz-1ph
TV-151	10	3/4	12	45	125	57	115/230V-60Hz-1ph
TV-142	21	1-1/2	30	113	225	102	230/460V-60Hz-3ph
TV-202	50	3	80	302	585	265	230/460V-60Hz-3ph

NOTE: Add "S" to end of model number for magnetic starter and selector switch

Vacuum Systems

VacMaster III Vacuum System

- Supplies conventional vacuum system pressure at a fraction of the cost
- Operates on shop air using Venturi effect to create vacuum pressure
- Holding force of approximately 13 lb per square inch at 25.5 inches of mercury
- In-line filters prohibit debris from entering the system
- Energy saver system – only consumes air when vacuum level falls below preset low limit
- Includes air inlet regulator/filter and vacuum filter cartridge

Vac-Master III Vacuum System – Specifications

CFM @58 psi: 4.2

Optimum feed pressure: 58 psi

Maximum supply pressure: 100 psi

Maximum vacuum: 26 Hg @ 58 psi

Working temperature: -4° to 176°F

Recommended chuck area: 250 square inches or less

Maximum holding force: 13 pounds per square inch



Permanent Magnetic Chucks

Fixed Permanent Magnetic Chucks

Uni-Mesh Permanent Magnetic Chucks

- Hold a wide range of parts
- Top plate provides a rigid and strong work surface – utilizes advanced technology electron beam welding
- Handle is easy to operate
- Low height
- Pole spacing
 - .250" wide major poles
 - .164" wide minor poles
 - .125" wide non-magnetic separators



Uni-Mesh Series – Specifications

Model	Size		Height		Weight	
	in.	mm	in.	mm	lb	kg
HUM-510	5 x 10	127 x 254	2-3/4	70	28	12
HUM-606	6 x 6	152 x 152	2-3/4	70	22	10
HUM-612	6 x 12	152 x 305	2-3/4	70	39	19
HUM-618	6 x 18	152 x 457	2-3/4	70	58	28
HUM-818	8 x 18	203 x 457	2-3/4	70	80	52

Fixed Permanent Magnetic Chucks

Micro-Mesh Permanent Chucks

- Most versatile magnetic chucks on the market
- Feature the closest pole spacing of any magnetic chuck
 - Major poles .125" wide
 - Minor poles .020" wide
 - Non-magnetic separators .010" wide
- Easily holds material as thin as .001"
- Also holds large parts extremely well



Micro-Mesh Series – Specifications

Model	Size		Height		Weight	
	in.	mm	in.	mm	lb	kg
HMM-510	5 x 10	127 x 254	2-3/4	70	27	12
HMM-606	6 x 6	152 x 152	2-3/4	70	22	10
HMM-612	6 x 12	152 x 305	2-3/4	70	40	19
HMM-618	6 x 18	152 x 457	2-3/4	70	58	28
HMM-818	8 x 18	203 x 457	2-3/4	70	76	52

Sine Equipment

Permanent Magnetic Sine Chucks

- For accurate angular machining, layout and inspection work
- Available in single angle (SP Series) or compound angle (DP Series)
- Can be manufactured with a choice of hinge arrangements
- Each unit is supplied with an inspection report and table of sine constants
- Come equipped with:
 - Hardened gage pads to accommodate gage blocks
 - Right hand screws for positive hinge roll locking
 - Removable end and back stops
- Available with Uni-Mesh and Micro-Mesh top plate pattern to insure holding of even the smallest or thinnest parts

Accuracy of Sine Equipment

- Parallelism in closed position for 6" x 6" models .0002" TIR, for 6" x 12" models .0003" TIR, for 6" x 18" models .0004 TIR
- Angular accuracies are ± 5 sec. @ 15° , ± 10 sec. @ 30° , ± 15 sec. @ 45°
- Hardened gage pad has .100" step to facilitate set up of small angles



SP Series, Single Angle – Specifications

Model	Work Surface (in.)	Height (in.)	Weight (lb)
SP-606UM	6 x 6	4-7/8	42
SP-606MM	6 x 6	4-7/8	42
SP-612UM	6 x 12	4-7/8	78
SP-612MM	6 x 12	4-7/8	78
SP-618UM	6 x 18	4-7/8	117
SP-618MM	6 x 18	4-7/8	117

UM: Uni-Mesh MM: Micro-Mesh



DP Series, Compound Angle – Specifications

Model	Work Surface (in.)	Height (in.)	Weight (lb)
DP-606UM	6 x 6	6-1/4	52
DP-606MM	6 x 6	6-1/4	52
DP-612UM	6 x 12	6-1/4	100
DP-612MM	6 x 12	6-1/4	100
DP-618UM	6 x 18	8	150
DP-618MM	6 x 18	8	150



Electromagnetic Chuck Repairs and Rebuilds

- Magna-Lock can repair and rebuild virtually any brand or size of electromagnetic chuck manufactured
- Bring existing chuck to "like new" condition for a fraction of the cost of new
- All rebuilds receive Magna-Lock's industry leading two-year warranty
- Often able to turnaround chucks in a matter of days, not weeks
- Loaner or rental chucks available to avoid downtime

Inspections of equipment also available.

Rectangular Rebuilds

- Includes new coils, new potting compound, new cord, new cord grip, new bolts and new gasket
- Regrind of sealing surfaces, paint

Rotary Rebuilds

- Includes new coils, new potting compound, new bolts, new gasket and new collector ring (if equipped)
- Regrind of sealing surfaces, paint

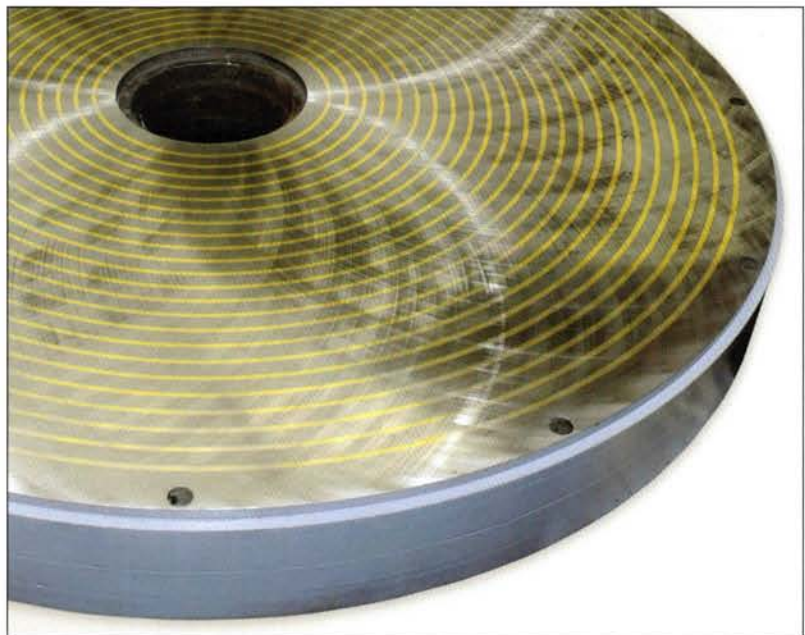



All sizes of electromagnetic chucks can be repaired/rebuilt.

Lift Magnet Rebuilds

- Can be restored to like-new condition for a fraction of the cost of new



MAGNALOCK

USA

2730 Eastrock Drive • Rockford, IL 61109
815.962.8700 • Fax: 815.398.0285
magnalock.com



MAGNALOCK

USA

2730 Eastrock Drive • Rockford, IL 61109

Fax: 815.398.0285

815.962.8700 • magnalock.com

Brochure 12 MLUSA